

CONTACT RESISTANCE METER

DAC-MR-100B

DAC-MR-50B



SOKEN Contact Resistance Meter, DAC-MR-100B and DAC-MR-50B are ideal for measurement at both laboratory and on-site test instantly and easily with the resolution 0.1 μ ohm.

Application

- Contact Resistance Measurement for Power Circuit Breaker (GIS, Switch Gear)
- Resistance Measurement for Bus Bar and Joint
- Conductive Resistance Measurement for Cables

Features

- Light and Durable, only about 8 kg
- Measuring Current 100A or 50A
- Resolution: 0.1 μ ohm
- Kelvin Clips for 4-Terminal Measurements

Model DAC-MR-100B/DAC-MR-50B CONTACT RESISTANCE METER

Specifications

	DAC-MR-100B	DAC-MR-50B
Measuring Range	0-1.9999 m ohm	0-1.9999 m ohm 0-19.999 m ohm
Measuring Current	DC100A±3%	DC50A±3%
Minimum Resolution	0.1μ ohm	
Accuracy	±(0.5%Rdg+3digits) at 1/10 of full scale or more ±(0.5%Rdg+10digits) at 1/10 of full scale or less	
Measuring Current Output	1.000V/100A	1.000V/50A
Display	4 1/2 digit (Max 1.9999)	4 1/2 digit (Max 19.999)
Power Consumption	800VA	410VA
AC Mains	AC 100V - 240V±10% 50/60Hz	
Size	W305xH245xD250(mm)	W305xH245xD250(mm)
Weight	8.4 kg	7.4 kg
Accessory	4 terminals Measuring Cable (5M) with Kelvin Clip x 1 set AC Cord (2M) x 1, Grounding Cable (2M) x 1 Operation Manual x 1, Accessory Bag x 1	

Principle

A standard resistor R_s is introduced into the resistance meter as in the circuit diagram. A common current I_s flows to both the resistor R_s and a specimen R_x under test. Thus, voltage drop generates separately: $I_s R_s = E_s$ for R_s , $I_s R_x = E_x$ for R_x .

The measured voltages, E_s and E_x are divided in the dividing circuit.

$$E_x/E_s = I_s R_x / I_s R_s = R_x/R_s$$

A ratio of R_x/R_s is given digitally.

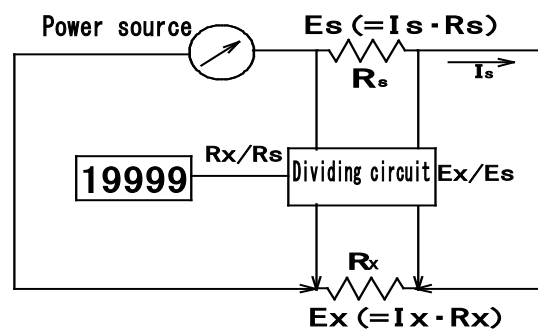

Connection image

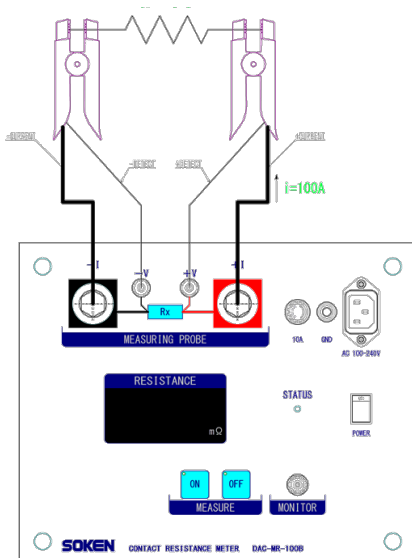

April 2025