

# Electronic Burden for Instrument Transformer

## Model DAC-PBVC-8

### ELECTRONIC BURDEN FOR INSTRUMENT TRANSFORMER



This electronic burden has been developed for error testing of instrument transformers (VT and CT). A ten-key pad is provided to facilitate the setting of parameters, such as burden, power factor, etc. In addition, since this device is equipped with a USB interface, an automatic test system can be configured by incorporating both test equipment for instrument transformer (DAC-VCTT-8) and a PC.

#### Features

- Can be used for both voltage transformers (VT) and current transformers (CT).
- Allows the setting of perfectly low burdens (zero burdens).
- Allows the setting in increments as small as 0.001 VA to the maximum of 100 VA.
- Lead-wire compensation is available when a two-terminal connection is used.
- Up to 100 sets of test conditioning parameters can be stored.

# Electronic Current Burden

## Specifications

- Rated secondary voltage: VT mode;  $110/\sqrt{3}$  V and 110 V
- Rated secondary current: CT mode; 1 A and 5 A
- Test voltage: VT mode; 2 to 120% of the rating  
CT mode; 1 to 120% of the rating
- Burden power factor: 0.20 (lag) - 1 - 0.80 (lead)  
Note: The burdens to be set under lead conditions must be 25 VA or less.
- Burden VA to be set: 0.000 to 100.0 VA
- Lead-wire compensation: 0 to 1.000  $\Omega$  under CT mode
- Burden setting accuracy:  $\pm 4\%$ , but  $\pm 10\%$  for 1/10 or less of the rating.
- Interface: USB (2.0/1.1).  
Note: GP-IB is also available on request.
- Test frequency: 50 Hz and 60 Hz
- AC Source: 100 to 240 VAC  $\pm 10\%$ , 50/60 Hz
- Power consumption: About 150 VA
- Operating environment: Temperature: 5 to 35°C; humidity: 35 to 80%, non-condensing
- Accuracy of voltmeter and ammeter:  $\pm (3\% \text{ reading} + 3 \text{ digits})$
- Size and weight: 430 (W)  $\times$  200 (H)  $\times$  450 (D) mm, about 26 kg

## Terminals, operation keys, and displays on the front panel

### DAC-PBCV-8

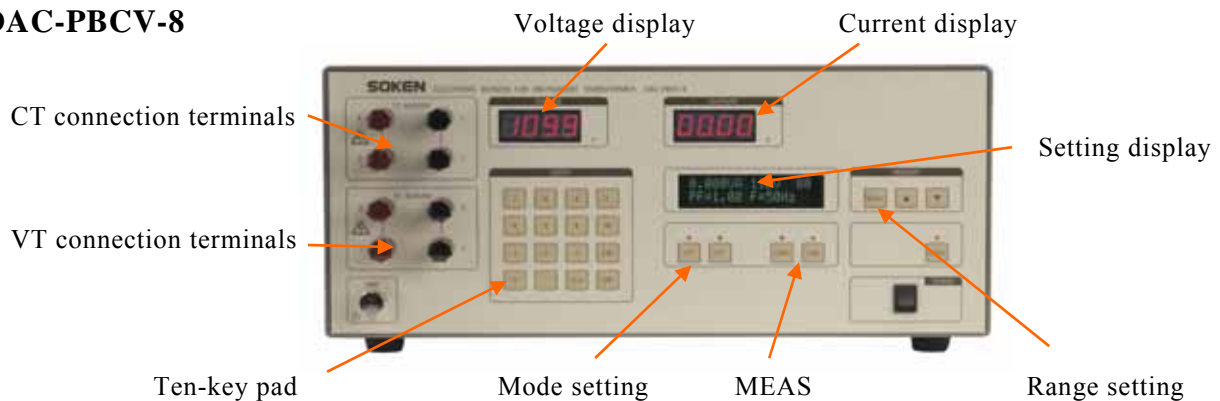

## Wiring diagram

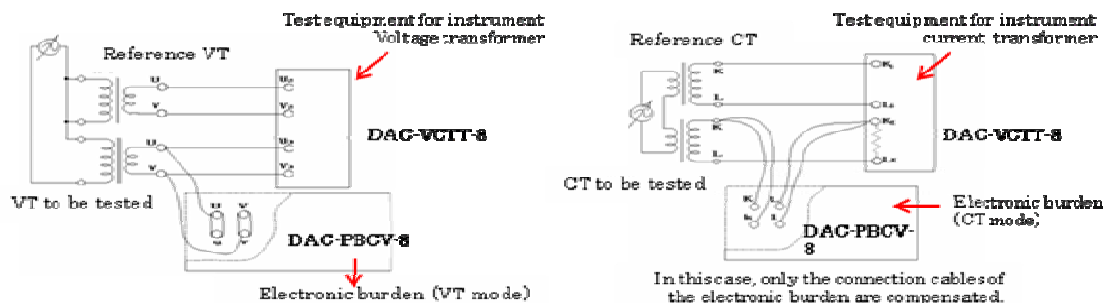

# Electronic Current & Voltage Burden

## Functions

This electronic burden features the advantages of two kinds of burdens (patent No. 3162307): a “real burden” constructed from resistance and reactance, and an “imaginary burden” created by electronic circuitry. This device allows automatic setting of burden at infinite resolution, which is difficult to attain with the real burden method. This device is compact and lightweight compared with a fully electronic version, because large capacity burdens can be generated using small-capacity electronic burdens. Furthermore, since the proportion of control capacity is small, stable burdens will be generated.

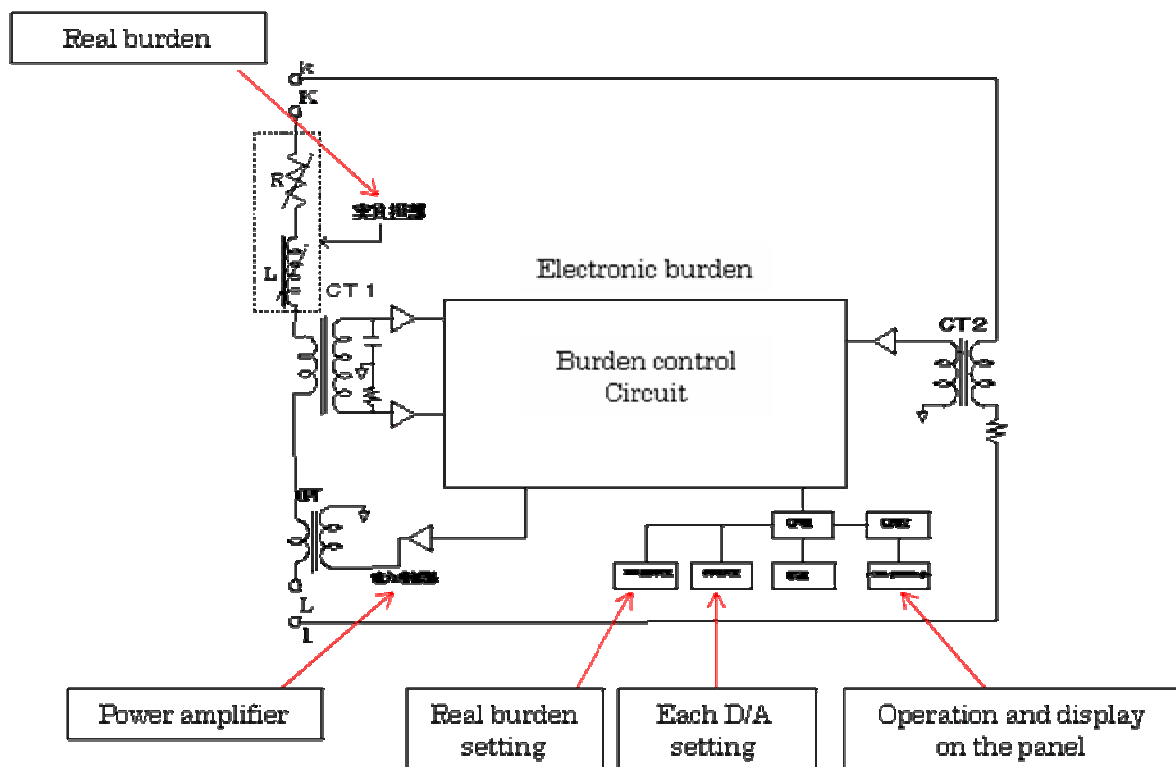

Schematic diagram of the main unit

In the above schematic diagram, the portion enclosed by a dotted-line rectangle is the effective burden unit made of a resistor (R) and a reactor (L); the rest, enclosed by a long dashed short dashed line, is the electronic burden (imaginary burden) unit. Both units are integrated into a casing.

When you set the value of a burden, the CPU automatically calculates and sets the values of resistance and reactance for which the output of the power amplifier is minimum. This means that large capacity burdens can be set at infinite resolution even with small power loss. In contrast to the four-terminal method commonly used with current-transformer burden systems, this device detects and takes into account the voltage drop between the current transformer to be tested and the electronic burden, and thus is able to provide the ideal setting of burdens.

# Electronic Current Burden

## Programmable electronic current burden DAC-PBC-8

### Profile

This instrument is an IEC 60044-1-compliant secondary burden device for current transformers for measuring instruments. It has USB interfaces as standard allowing construction of an automatic test system in combination with PCs.



### Features

- Programmable burden used for current error testing in accordance with international standard IEC 60044-1.
- Testing current can vary over a wide range: From 1% to 200% of the rated secondary current.
- Rated burdens from 0 to 50 VA are programmable.
- USB interfaces are included as standard.
- Test conditions can be easily configured; a maximum of 100 test parameters (rating, burden, power factor and lead wire compensation) are programmable.
- Lead wire compensation (a maximum of 0.2  $\Omega$ ) for connection of two terminals is possible.

### Specifications

- Rated secondary current: 1 and 5 A
- Test current range: 1% to 200% of the rated secondary current
- Rated burden setting: 0.000 to 50.0 VA
- Burden power factor: Delay: 0.50 to 1
- Lead wire compensation: 0.000 to 0.200  $\Omega$
- Test frequency: 50/60 Hz
- Settable resolution: Rated burden setting
  - 0 to 4 VA: 0.001 VA steps
  - 4 to 20 VA: 0.01 VA steps
  - 20 to 50 VA: 0.1 VA stepsBurden power factor
  - 0.01 steps
- Accuracy (target value): Burden and burden power factor:  $\pm 4\%$
- Communication: USB (2.0/1.1)
- Other functions: Test condition programming, overcurrent protection, alarm function for measuring circuits, and lead wire compensation.
- Rated supply voltage: 100 to 240 V  $\pm 10\%$
- Power supply frequency: 50/60 Hz
- Dimensions: W 430 mm x H 200 mm x D 380 mm (excluding the protruding portion)

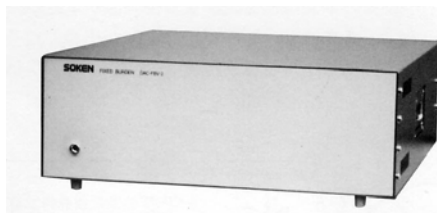

### Option for DAC-PBC-8

DAC-PBC-8 has the maximum 50VA, and please add an optional burden in need of further VA.

- DAC-FBC-50, 50VA
- DAC-FBC-100, 100VA

Maximum 400VA is available, where one DAC-PBC-8(50VA)+one DACFBC-50(50VA)+three DAC-FBC-100 are to be combined.

# Electronic Voltage Burden

## Programmable electronic voltage burden DAC-PBV-8

### Profile

This instrument is an IEC 60044-2-compliant secondary burden device for voltage transformers for measuring instruments. It has USB interfaces as standard allowing construction of an automatic test system in combination with PCs.



### Features

- Programmable burden used for voltage error testing in accordance with international standard IEC 60044-2.
- Testing voltage can vary over a wide range: 2% to 190% of the rated secondary voltage.
- Burdens from 0 to 75 VA are available standalone, or a maximum of 400 VA in steps of 100 VA is available with optional electronic burdens.
- USB interfaces are included as standard.
- Test conditions can be easily configured; a maximum of 100 test parameters (rating, burden, power factor and lead wire compensation) are programmable.

### Specifications

- Rated secondary voltage: 100, 110, 115, 120, 200, 230 V, and each of these voltage x  $1/\sqrt{3}$ ,  $100/3$ ,  $110/3$  and  $200/3$  V
- Test voltage range: 2% to 190% of the rated secondary voltage; maximum current of 12 A
- Rated burden setting: 0.00 to 100.0 VA  
Maximum of 400 VA\* with an optional burden enhancer  
\* Except rated secondary voltages of 200, 230,  $200/\sqrt{3}$  and  $230/\sqrt{3}$  V
- Burden power factor: Delay: 0.20 to 1 [Rated burden: 0 - 35 VA]  
Delay: 0.5 to 1 [Rated burden: 35 - 75 VA]  
Delay: 0.8 [With option, Rated burden: 75 - 400 VA]
- Test frequency: 50/60 Hz
- Settable resolution: Rated burden setting  
0 to 4 VA: 0.001 VA steps  
4 to 20 VA: 0.01 VA steps  
20 to 75 VA: 0.1 VA steps  
With an optional burden enhancer  
75 to 99.9 VA: 0.1 VA steps  
100 to 400 VA: 1 VA steps  
Burden power factor  
0.01 steps
- Accuracy (target value): Burden and burden power factor:  $\pm 4\%$
- Communication: USB (2.0/1.1)
- Other functions: Test condition programming, overcurrent protection, and alarm function for measuring circuits
- Rated supply voltage: 100 to 240 V  $\pm 10\%$
- Power supply frequency: 50/60 Hz
- Dimensions: W 430 mm x H 250 mm x D 380 mm (excluding the protruding portion)
- Option: Electronic Burden (DAC-FBV-A/B/C100) 100 VA each.  
Maximum 400VA

# Ratio Adaptor



## Ratio Adapter DAC-RAC-2

### Profile

This instrument is an optional unit for the Automatic Instrument Transformer Test Set DAC-VCTT-8. DAC-RAC-2 makes a tests available when the transformation ratio  $K_S$  of a standard current transformer and the transformation ratio  $K_X$  of a tested current transformer are different by setting a ratio  $K_S/K_X$  and making necessary conversions so that the transformation ratios become equal.

### Specifications

- Settable ratio range ( $K_S/K_X$ ): 0.5000 to 2.0000  
 $K_S$ : Transformation ratio of the standard current transformer  
 $K_X$ : Transformation ratio of the tested current transformer
- Accuracy\* (target value): Ratio error:  $\pm (0.002 \% + 3 \text{ digits})$   
Phase angle:  $\pm (0.1 \text{ min.} + 1 \text{ digit})$   
\* Effects on measured values of Automatic Instrument Transformer Test Set DAC-VCTT-8 when using this instrument.
- Dimensions: W 430 mm x H 150 mm x D 380 mm (Excluding the protruding portion)
- Weight: approx. 15 kg

## Ratio Adapter DAC-RAV-2

### Profile

This instrument is an optional unit for the Automatic Instrument Transformer Test Set DAC-VCTT-8. DAC-RAV-2 makes a tests available when the transformation ratio  $K_S$  of a standard voltage transformer for measuring instruments and the transformation ratio  $K_X$  of a tested voltage transformer for measuring instruments are different by setting a ratio  $K_S/K_X$  and making necessary conversions so that the transformation ratios become equal.

### Specifications

- Settable ratio range ( $K_S/K_X$ ): 0.5000 to 2.0000  
 $K_S$ : Transformation ratio of the standard voltage transformer for measuring instruments  
 $K_X$ : Transformation ratio of the tested voltage transformer for measuring instruments
- Accuracy\* (target value): Ratio error:  $\pm 1 \text{ digit}$   
Phase angle:  $\pm 1 \text{ digit}$   
\* Effects on measured values of Automatic Instrument Transformer Test Set DAC-VCTT-8 when using this instrument.
- Dimensions: W 430 mm x H 150 mm x D 380 mm (Excluding the protruding portion)
- Weight: approx. 10 kg



Head Office and Factory  
ISO9001 Certificate Obtained

**SOKEN** SOKEN ELECTRIC CO., LTD

3-57-124, Kamiishihara, Chofu-shi, Tokyo 182-0035

TEL: +81-42-490-6929 (Sales direct) FAX: +81-42-490-6807

E:Mail : s2258@soken-jp.com <http://www.soken-jp.com>