

INVERTER HOT LINE COIL RESISTANCE METER DAC-HRI-3



DAC-HRI-3 can measure resistances of the coil winding of a motor driven inverter power supply (PWM) during applying voltage.

Generally, either the temperature measuring method which measures a partial temperature by using temperature sensor, or the resistance method which measures resistance and converts it by using temperature coefficient, is introduced to temperature rise test of motor. Comparing these 2 methods, the former one is easily influenced by an environmental temperature. DAC-HRI-3, introducing the later method, can measure resistance of the coil windings directly and obtain precise resistance values. Besides, DAC-HRI-3 can measure resistance without turning off the power, it is enable you to have the **true** temperature of a whole driven motor coil efficiently.

Test Materials

- EV Motor
- Brushless Motor
- Compressor Motor for Air-Conditioner

Related Standard

- JIS C4203 Single Phase induction motors
- JEC 2137 Induction motor
- JEC 60034-1 Rotating electrical machines - Part 1: Rating and performance

Principals

A DC-blocking capacitor is inserted to prevent flow of the DC measuring current into the AC power source, and the energizing AC voltage is applied to the coil, Lx, of the tested motor. A DC current from the DC constant current circuit of the Coil Resistance Meter is superimposed on the coil, Lx, and the voltage drop across the Lx is measured. The DC component of the measured voltage drop is extracted by using a low pass filter (LPF), and then the coil resistance is calculated and displayed. Because the LPF is composed of circuit elements, a CPU-based digital filter is used to eliminate inverter noises.

Specifications

- Measuring range : 0.2Ω Range : 0-0.2000Ω (Superimposed Current DC100mA)
 2Ω Range : 0-2.000Ω (Superimposed Current DC100mA)
 20Ω Range : 0-20.00Ω (Superimposed Current DC10mA)
 200Ω Range : 0-200.0Ω (Superimposed Current DC1mA)
 2000Ω Range : 0-2000Ω (Superimposed Current DC0.1mA)
- Testing Voltage : Max AC450V* (50/60Hz)
 *Max 700V type is available as option. (Model DAC-HRI-3 Type 700)
- Frequency : 10 - 400Hz
- Resolution : Voltage Meter : 0.1V
 Resistance Meter : 0.1mΩ (0.2Ω Range)
- Display : Voltage Meter : 4 digit
 Resistance Meter : 4 digit 2000FS
- Accuracy : 2Ω/20Ω/200Ω : ±0.3% FS
 0.2Ω Range : ±0.5% FS
- Input impedance : 0.2Ω/2Ω Range : Approx. 1.5kΩ
 20Ω Range : Approx. 15kΩ
 200Ω Range : Approx. 150kΩ
 2000Ω Range : Approx. 1500kΩ
- Interface : RS232C
- Analog output : DC0-2V
- Power Source : AC100V-240V±10% 50/60Hz
- Dimensions : W430×H200×D385mm Approx. 20kg
- Accessories : 1) 4-terminal probe (6m)
 2) AC Power cable (3P inlet cord with a ground terminal)
 3) Instruction manual
 4) Inspection certificate (Test Report)
- Option : DC Blocking Capacitors Box (C-BOX, 7A, 23A, 45A)

Conversion to temperature

Usually, $1/\alpha_0 = 234.5$, where α_0 is the temperature coefficient at 0°C, is used for the conversion to temperature as described in the following formula.

$$t_c = \frac{R_t - R_{t_0}}{R_{t_0}} (235 + t_0) + t_0$$

$\Delta t = t_0 - t_e$
 t_c = Converted temperature (T_c)
 Δt = Temperature rise (ΔT)
 R_t = Measured electrical resistance (R)
 R_{t_0} = Initial resistance (R_0)
 t_0 = Initial temperature (T_0)
 t_e = Environmental Temperature

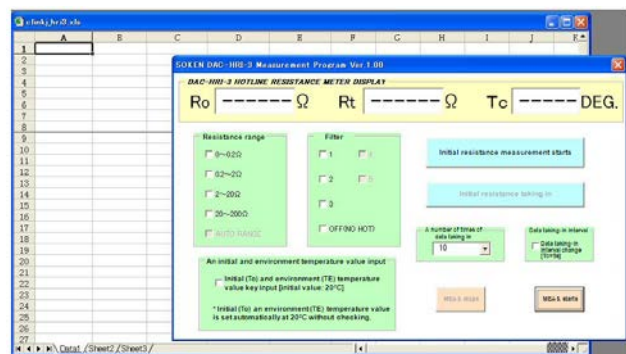

Conversion to Temperature is possible by input the Initial Resistance value and initial Temperature value through PC by using sample software. Measured values with time are saved and displayed in an Excel Sheet.

DC Blocking Capacitors Box

DC Blocking Capacitor must be required for measurement under energized. An appropriate capacitor must be selected in accordance with the rated current of specimen.

- Capacitor : Electrolytic Capacitor
- Maximum-allowed-current value
 - : 470 μ F ... 2A
 - : 4,700 μ F ... 7A
 - : 47,000 μ F ... 23A
 - : 330,000 μ F ... 45A

Model DAC-C23AXC7A (For 3 Phase 23A/7A)



Optional Capacitors for single phase, 3-phase, and large current specification etc, are also available.

About Hot-Line resistance measurement

The conventional temperature rise test of motors has to be turned off the power every time to measure the resistances. However, a coil cools rapidly and its resistance also changes promptly once turning off the power. In case a fan is equipped with a motor, the motor exterior is cooled by the fan, and there could be large differences with the actual temperature of the coil inside the motor. SOKEN Hot-Line resistance meters can measure resistance without turning off the power, and changes of resistance at the real time can be obtained. DAC-HRI-3 is an ideal meter to achieve the true temperature of a whole driven motor coil efficiently.

Why superimpose a DC component on the AC line

It is not impossible to derive effective resistance from AC components under the energized state, but the derivation is associated with difficulties related to load conditions or separation of iron loss. In addition, pertinent electrical regulations stipulate that copper wire resistance must be DC measured. For this reason, this Coil Resistance Meter adopts the approach of superimposing a DC component on the AC line. The magnitude of the DC current to be superimposed, however, is made negligible to the AC current.

Connecting Diagram

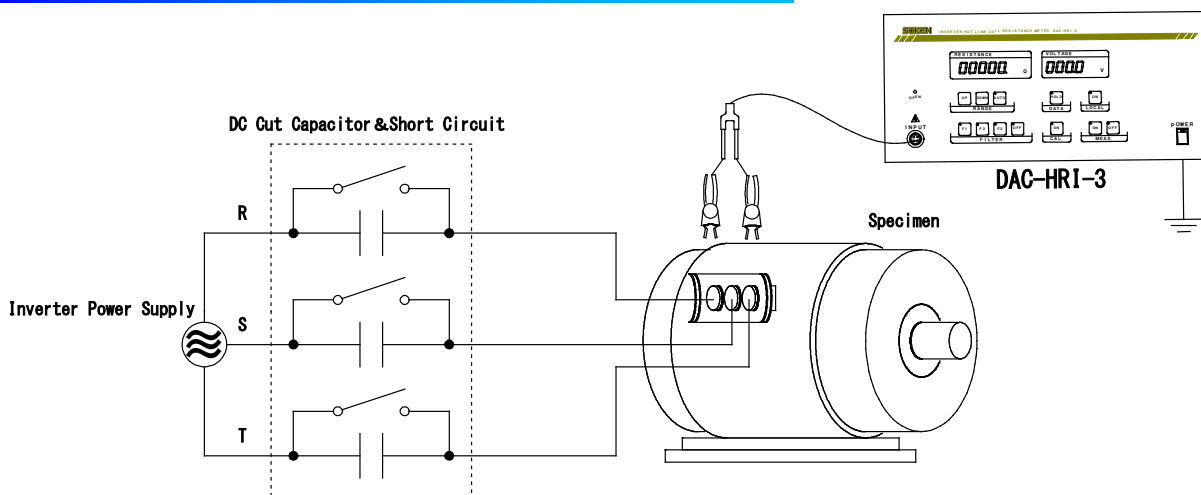

DAC-HRI-3 INVERTER HOT LINE COIL RESISTANCE METER

Option Switching Box with Software for AUTO 3-phase measurement

Automatic 3-phase measurement is available with option Switching Box.

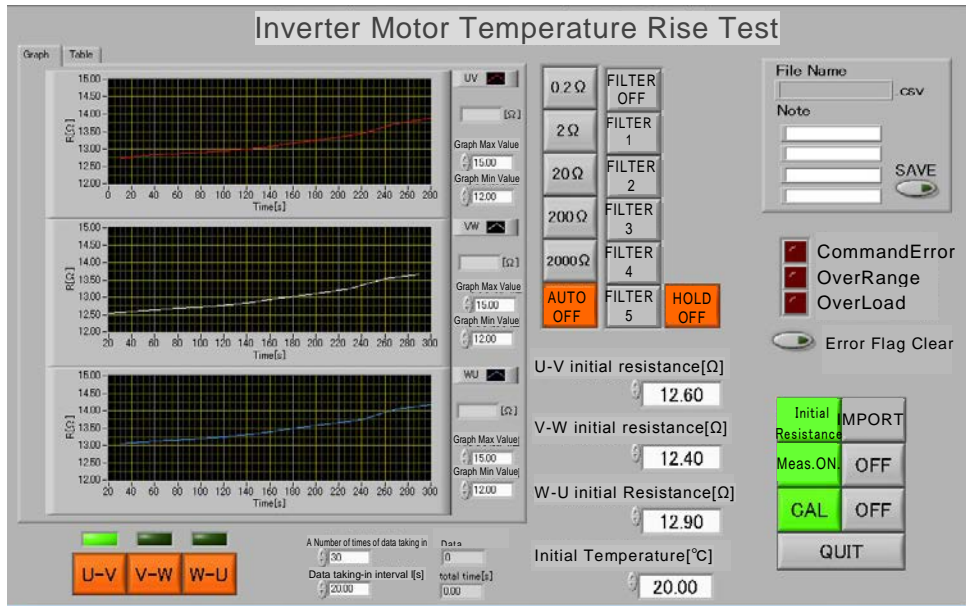

Auto Measuring Software (PC display image)

- Continuous Measurement to obtain Temperature Rise – Cooling Curve.
- Automatic switchover of 3-phase (U-V, V-W, U-W).
- Data acquisition of 1 selected phase at minimum sampling time.
- Time Interval and a number of times of import data are configurable.
- Conversion to Temperature only by input the Initial Resistance value and initial Temperature value.

Connecting Example

When use 3-phase switching Box with Capacitor Box.

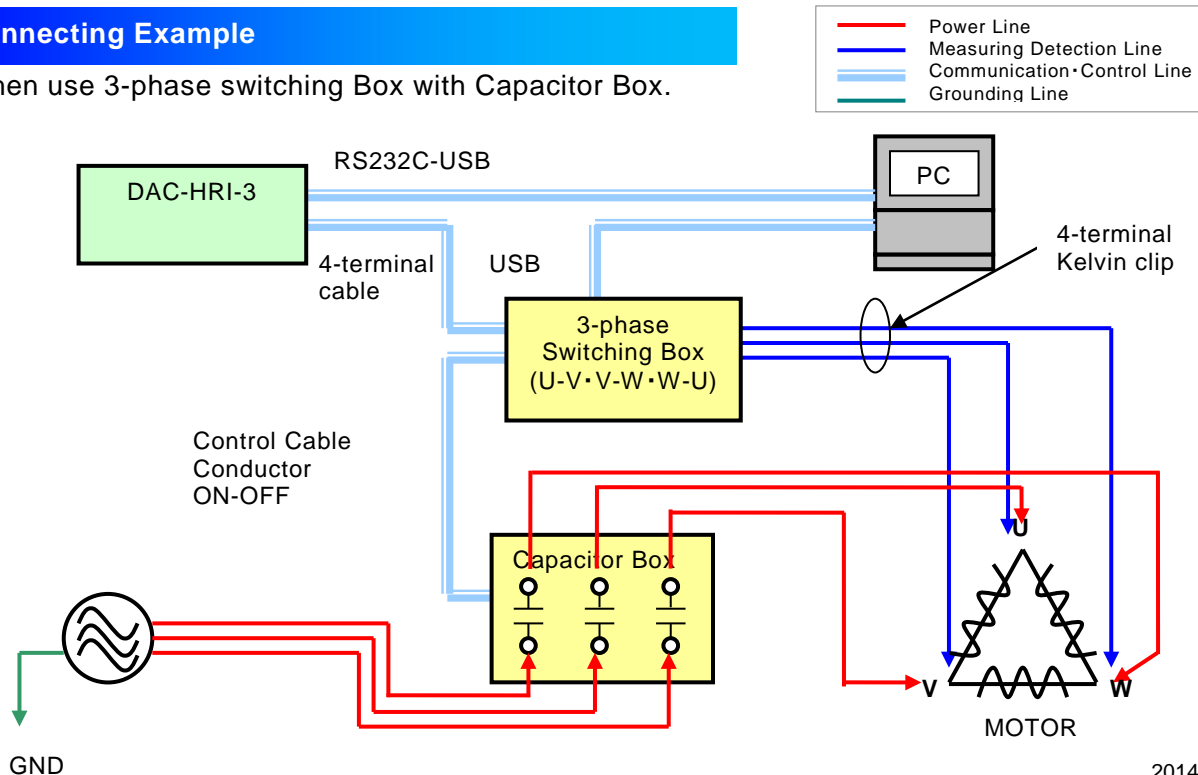

2014/07/22