

# LAMINATION STATOR TESTER DAC-LST-3



DAC-LST-3 is designed for a pass/fail judgment test of lamination stators of motors by comparison with a reference (\*).

A built-in exciting source gives B (Magnetic Flux Density) and H (Magnetizing Force) to read W (Iron Loss). PWM inverter being introduced for the source, DAC-LST-3 is smaller than the last passive transformer type.

Moreover, as in all-in one type, no external stabilizing source is necessary. The frequency is changeable in the range of 50Hz to 400Hz.

An USB interface is provided as standard, and data acquisition and transmission from a PC is possible.

(\* ) The reference stator shall be sampled from your product and preset on the tester.

## Test specimen

Lamination Stator-Core of Motors

## Features

- Magnetic characteristic (B-H-W) can be judged by easy operation, and management of quality of stator cores is possible.
- The frequency of the exciting power supply in range of 50 Hz to 400 Hz.
- Adjustment of the exciting power supply can be performed smoothly.
- Judgment result with a preset value and a measurement value is displayed intelligibly on an LCD panel.
- Acquisition of measuring data and transmission of preset values from a PC is possible by using USB interface.

## Specifications

Measuring range	B (Magnetic Flux Density)	0 - 2.0T
	H (Magnetic Field Strength)	0 - 400A/m
	W (Core Loss)	0 - 15W/kg
Measuring accuracy	<math>\pm 2.5\%</math> by electric calibration	
Measuring Frequency	50Hz-400Hz	
Specimen size	Magnetic Path (LENGTH)	20.0 to 999.9mm
	Lamination (THICKNESS)	20.0 to 100.0mm
	Magnetic Width (WIDTH)	5.0 to 60.0mm
	Inner diameter of Stator	>50mm
Input Voltage	AC200V $\pm$ 10% 50/60HZ (when at AC100V, there are some limitations in specifications.)	
Consumption	Max 2kVA	
Size & weight	W427 x D450 x H295mm, 35kg	
Accessory	Measuring cable with probe (50mm in diameter), Checking resistor box, Power Code, Sample software	
Options	Test Bench (Air cylinder probe, Stator Palletx3)	

## Judgment Mode & LCD Display

MAGNETIC FLUX DENSITY	*. ** mT
MAGNETIC FIELD STRENGTH	*. ** A/m
CORE LOSS	*. *** mW/kg
<input checked="" type="checkbox"/> LEVEL: 0.00% <input type="checkbox"/> AUTO MEAS. <input type="checkbox"/> OFF FREQUENCY: 50Hz    INTERFACE: INT TOOL	
DENSITY 7.85 g/cm <sup>3</sup> <B-MODE> THICK. 50.4 mm B TARGET 1.20 T WIDTH 50.6 mm H U. LIMIT 500 A/m LENGTH 117.8 mm W U. LIMIT 2.00 W/kg	

### MODE Selection

**B-MODE**: Fix B value, and measure H and W.

**H-MODE**: Fix H value, and measure B and W.

Judgment measurement can be performed by comparing a reference value input in the tester.

*Example:*

When B-MODE, input an optional value of Magnetic flux density (B), and set upper limit values of both Magnetic field strength (H) and Core loss (W). When measured value is within the limit, indication lamp lights in green, if less than the limit, the lamp lights in yellow.

## Size of Stator

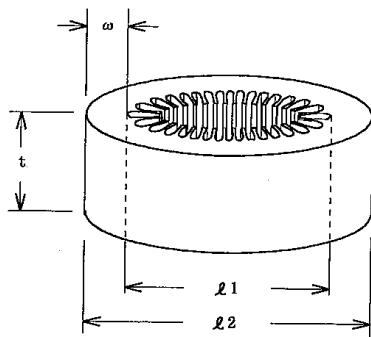

Fig. 1

(l1: inside diameter of stator, l2: outside diameter of stator)

When measure a stator like Fig 1, Magnetic Path length, Lamination Height and Magnetic width must be set as follows.

$L = (l1 + l2) * \pi / 2$  : Setting of LENGTH  
 $T = t$  : Setting of THICKNESS  
 $W = \omega$  : Setting of WIDTH  
 (at the narrowest part)

2022/12/26